

12 TYPICAL WINDOW HEAD
SCALE: 3" = 1'-0"
DETAIL_CONNECTION.DWG

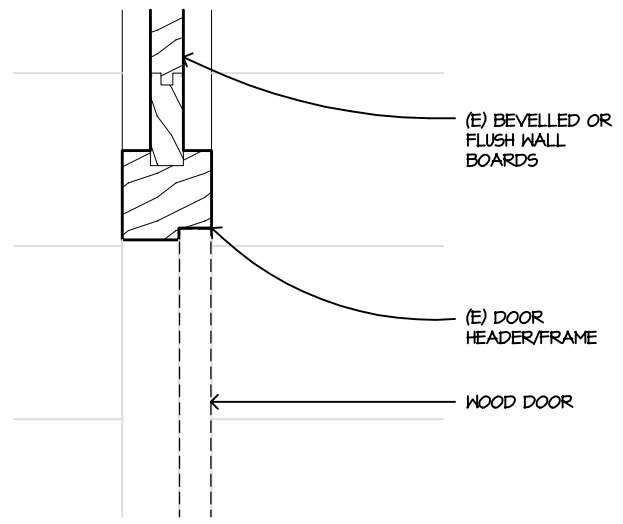

9 TYPICAL DOOR HEAD
SCALE: 3" = 1'-0"
DETAIL_CONNECTION.DWG

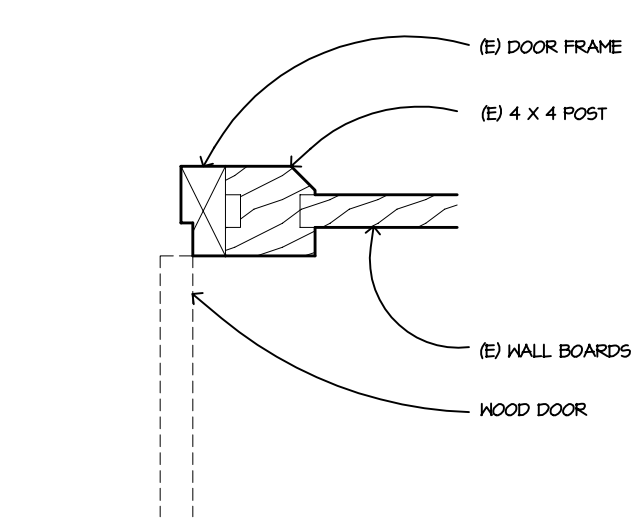

6 TYPICAL DOOR JAMB
SCALE: 3" = 1'-0"
DETAIL_CONNECTION.DWG

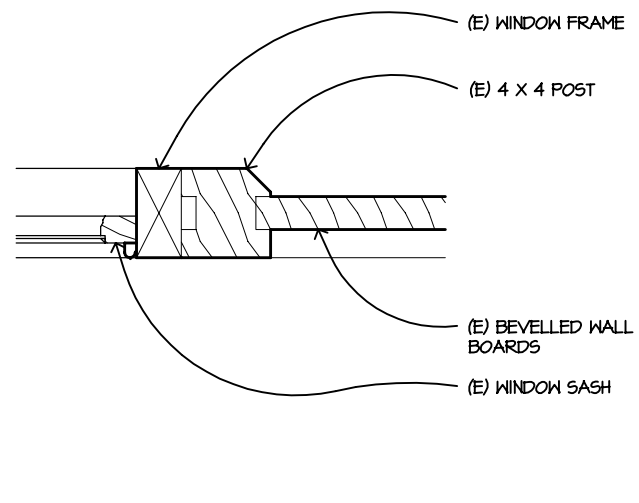

11 TYPICAL WINDOW JAMB
SCALE: 3" = 1'-0"
DETAIL_CONNECTION.DWG

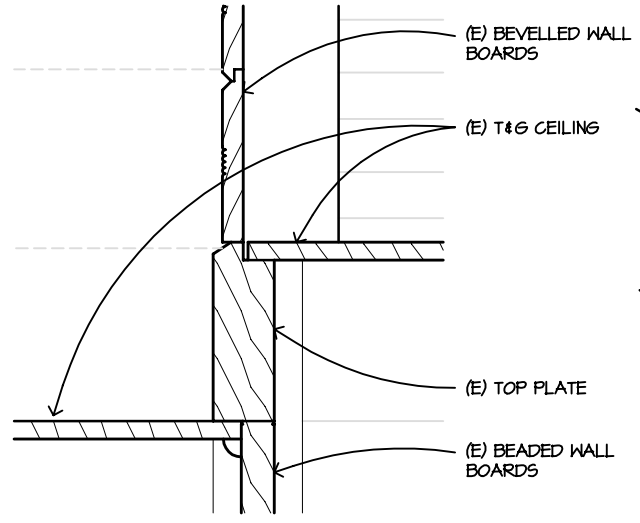

8 TOP PLATE AT NORTH GABLE END
SCALE: 3" = 1'-0"
DETAIL_CONNECTION.DWG

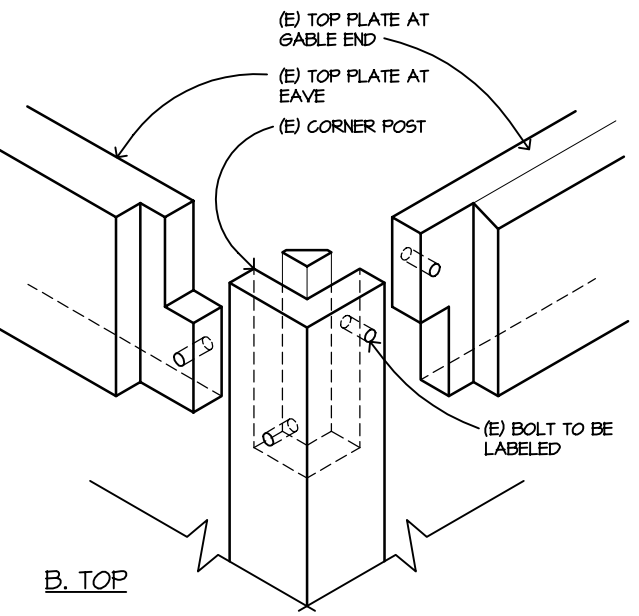

4 CORNER POST CONNECTION
SCALE: 3" = 1'-0"
DETAIL_CONNECTION.DWG

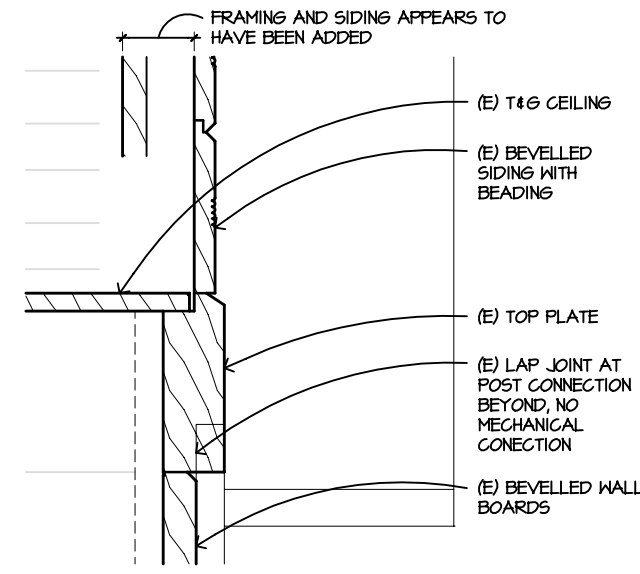

2 TOP PLATE AT SOUTH GABLE END
SCALE: 3" = 1'-0"
DETAIL_CONNECTION.DWG

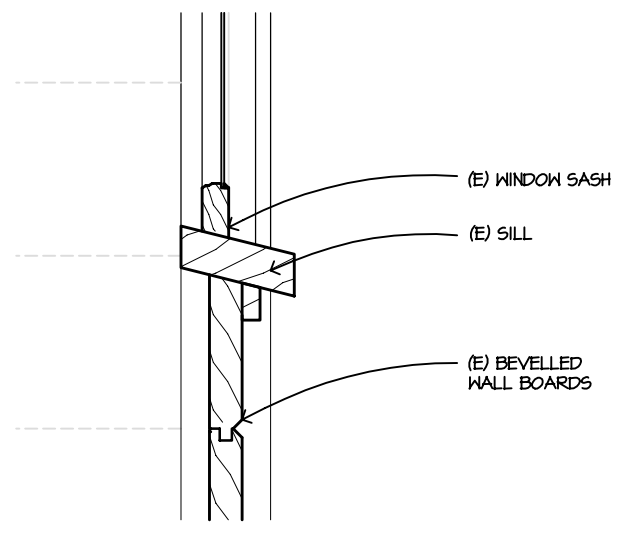

10 TYPICAL WINDOW SILL
SCALE: 3" = 1'-0"
DETAIL_CONNECTION.DWG

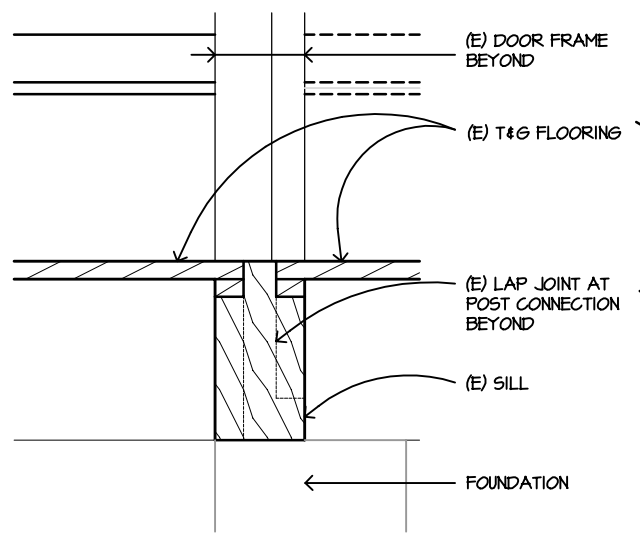

7 WALL SILL
SCALE: 3" = 1'-0"
DETAIL_CONNECTION.DWG

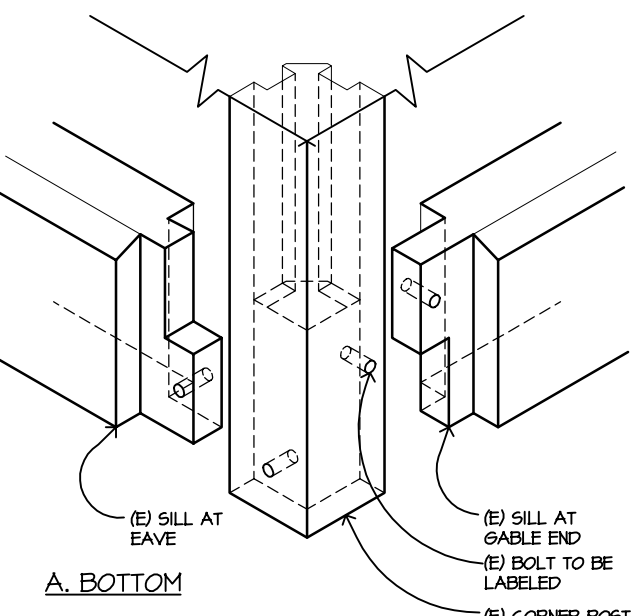

4 CORNER POST CONNECTION
SCALE: 3" = 1'-0"
DETAIL_CONNECTION.DWG

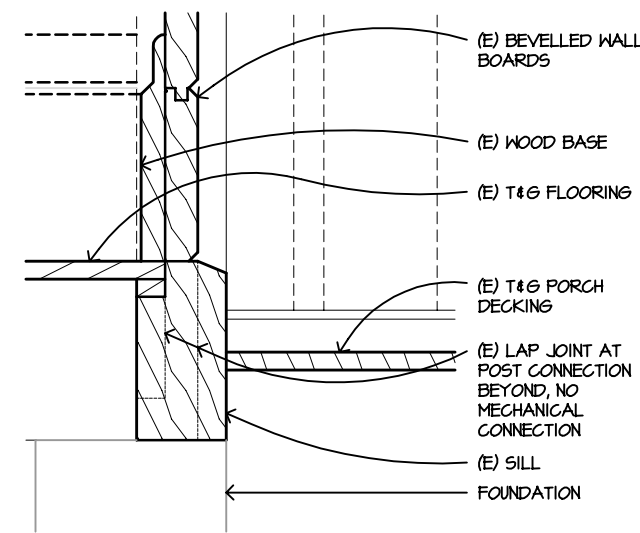

1 TYPICAL WALL SILL
SCALE: 3" = 1'-0"
DETAIL_CONNECTION.DWG

NO.	DESCRIPTION	DATE
REVISIONS		

KENNEY COTTAGE
HISTORIC AND EXISTING CONDITIONS
1719 UNIVERSITY AVENUE
BERKELEY, CALIFORNIA

SHEET TITLE
DETAILS

ISSUANCE
100% DOCUMENTATION DRAWINGS
DATE
June 20, 2002

PROJ. NO. 02063	
DRAWN JB/JC	
CHECKED JJ/JC	

DRAWING NO.
A8.1
SHEET 4 OF 4